



Skim-Line™ Deluxe Thru-Wall Skimmer

Models 0-2094-023 / 0-2094-025

Owner's Guide

PICKUP PHOTO FROM PREVIOUS OWNER'S
GUIDE
P/N 365-1860

Your new Doughboy Thru-Wall Skimmer makes pool maintenance easier and more convenient. Leaves, insects and floating debris are pulled from the pool into the skimmer basket. Clean the basket regularly to help your pool stay sparkling clean and sanitary. The numbers in parentheses (00) refer to key numbers in the illustration on page 5.

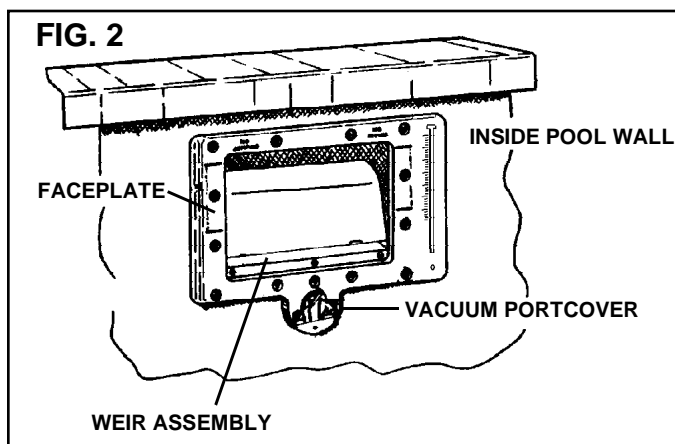
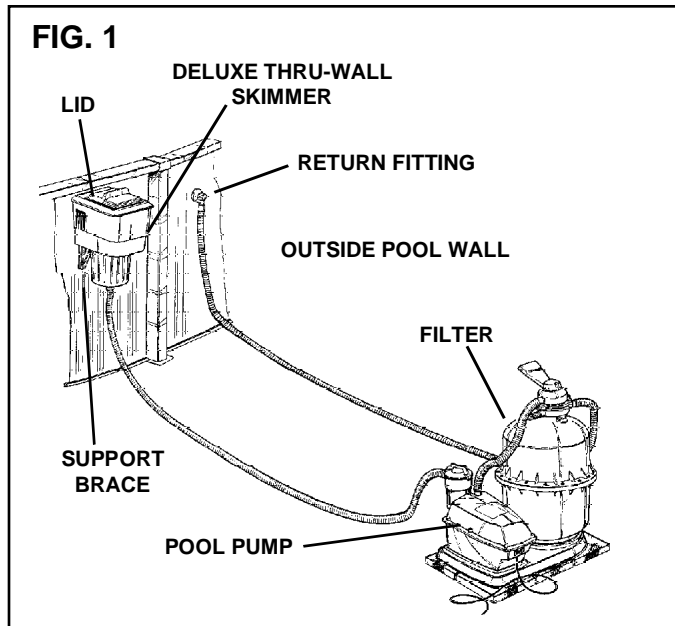

Tools You Will Need

- Large Nail (Approx. 2" Long)
- Flat Head Screwdriver
- Phillips Screwdriver
- Razor Knife

POOL PREPARATION

The pool must be properly erected per Doughboy's Pool Assembly & Installation Instructions. There should be a minimum of 5" but less than 2 ft. of water up the pool wall so the liner is under weight and stretched to the proper position prior to installing skimmer.

NOTE: The liner cannot be shifted after the skimmer holes have been cut.

SKIMMER INSTALLATION

1. Remove all components from carton. Remove lid from skimmer by sliding forward and lifting. Remove basket and hardware package from skimmer.

2. Attach weir assembly (25) to skimmer (6) using three screws (17). Push weir inside so that the foam side is down.

3. If you are installing onto a Doughboy Classic 8-1/2" or an Impressions pool, you will need to use a Doughboy Skimmer Extension (Model # 0-2351-001 or 0-2351-002) with this skimmer. The instructions provided with the extension will replace steps 9 and 10 of this owner's guide. Refer to those instructions at this time to proceed with installation. When you have finished that portion of the assembly, return to step 11 in this owner's guide to complete skimmer and return fitting installation.

4. To install the upper faceplate u-gasket, trim the liner from the skimmer opening **leaving the entire bottom edge uncut** (see Fig. 3). Pass the hanging liner material through the skimmer opening to outside the pool wall. Pull down firmly and tape securely with duct tape as shown.

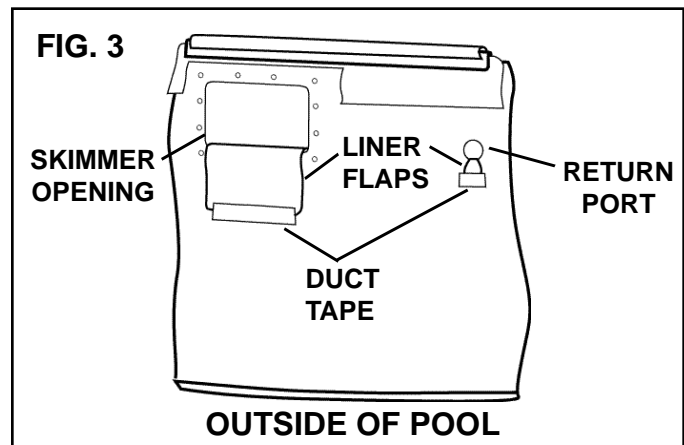

5. Install the upper faceplate u-gasket into the rectangular wall opening (see FIG. 4). Be sure the liner is flattened under the gasket's flanges.

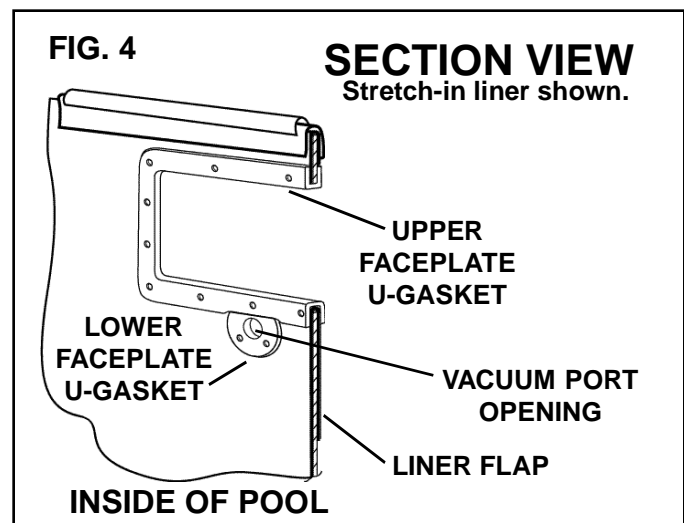

6. Hold a board behind the round vacuum port wall opening located just below the large rectangular opening. From the opposite side, completely trim the liner material (2 layers) from the wall opening.

7. Install the lower faceplate u-gasket (vacuum port) into the previously cut opening.

8. With both skimmer gaskets installed, trim away the excess liner material (outside of pool) using the gasket edges as a guide.

9. Punch out the two top corner upper gasket holes using a nail. Position the faceplate (20) over the gaskets and insert two large self-threading screws (19) into top corner

holes and carefully push the screws through the holes which have been pierced in the liner. From outside the pool, align the skimmer body with these screws. Lightly tighten the two screws (Fig.5).

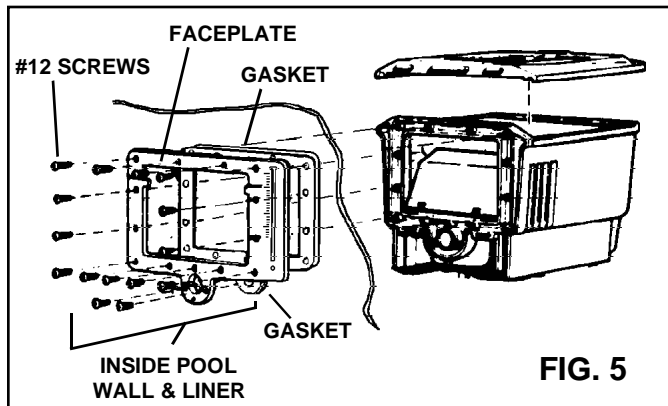

10. Using a nail and the faceplate as a guide, pierce the 13 additional holes through the liner. Insert and lightly tighten the remaining 13 screws (19) through the faceplate, gaskets, liner, pool wall, and into corresponding holes on the skimmer. Tighten all screws firmly and evenly, alternating left and right, top and bottom.

NOTE: The gasket around the vacuum adaptor is required to assure a tight seal around the vacuum adaptor when vacuuming.

11. Attach vacuum port cover (15) and retainer (16) to faceplate using screw (17).

RETURN FITTING INSTALLATION

1. From inside the pool, hold a board against the return port. Using the edge of the wall opening as a guide, cut the liner around the opening leaving approx. 1/4" of material uncut at the bottom of the opening. Pass the liner flap through the opening to outside the pool wall, and tape down the liner flap as shown (see Fig. 3).

2. Install the return fitting u-gasket (12) into the wall opening making sure the liner's edge is trapped under the gasket. Insert the threaded end of the return fitting adaptor (11) through the wall from inside pool.

3. Hold the return fitting body (13) so the hose fitting end points straight up while turning the adaptor from inside the pool. When the adaptor just begins to crush the gasket, hold the adaptor from turning while rotating the body clockwise to its straight down position.

4. If the assembly does not feel snug, rotate the return fitting body back to the up position. Rotate the adaptor inside pool an additional 1/4 turn, then rotate the body to the down position again. Repeat this procedure as required.

5. Install eyeball insert (14) into eyeball (9). Hold the eyeball inside the adaptor (11) with insert toward inside. Thread on the return fitting cover (8) to secure eyeball position so it directs flow away from skimmer opening. Do not overtighten.

CONNECTING SKIMMER TO FILTER

Install the filter and pump as far from the pool wall as possible so they may not be used as steps by children. Instructions in your Filter Owner's Guide will tell you how to connect the skimmer to the filtering system. Follow those instructions carefully. When you have completed them,

refer to Doughboy's Pool Assembly & Installation Instructions to fill pool. The correct water level will be midway between the two water level marks on the skimmer faceplate. Inspect skimmer installation for leaks when pool is filled. On-going leaks from skimmer or wall fittings may cause pool wall damage which eventually may result in pool wall failure.

CAUTION: Always keep the water level in your pool between the water level markers on the skimmer faceplate. The pump must be able to draw water from the pool to operate. Never run the pump with the pool water level so low that no water passes to the pump. This may cause the pump seal to overheat and could result in permanent damage.

ROUTINE CARE & MAINTENANCE KEEP YOUR POOL SPARKLING

You can take steps to reduce the amount of maintenance needed to keep your pool sparkling.

1. Provide a clean walkway leading to your pool entrance.
2. Rinse off patio and area around pool regularly.
3. Bathers should rinse off (especially their feet) before entering pool.
4. Maintain the proper chemical balance in your pool. Hot days will cause chemicals to dissipate rapidly.
5. Remove floating leaves and debris with a leaf skimmer.
6. Empty skimmer basket frequently.
7. Vacuum pool bottom to remove settled debris.

DOUGHBOY POOL CARE

Refer to Doughboy's "Read Me First for Pool Safety Handbook" for correct use, care, and chemical treatment of Doughboy pools.

CHLORINE INSTRUCTIONS ALWAYS READ AND FOLLOW CHEMICAL MANUFACTURER'S SAFETY PRECAUTIONS FOR HANDLING CHLORINE

WARNING! DO NOT PLACE CHLORINE TABLETS IN THE SKIMMER BASKET! Putting chlorine tablets directly into the skimmer basket will destroy the basket and internal components. We recommend against adding any kind of chemicals directly into the skimmer! Please read the following instructions carefully. Chlorine is a strong chemical. Improper use could result in serious, permanent damage to the pool liner. This damage could include "white spots", wrinkles or breakage (brittle vinyl). Such damage is not covered under warranty.

IMPORTANT: Pump should always be "ON" when adding any chemicals to pool water.

WITH DISPENSER

Dry Chlorine (tablets, sticks, granules, or powder). Use one of the following types of chlorine dispensers:

- Floating Dispenser: Use only when pump and filter are running. Dispenser must circulate in pool for safe distribution of chlorine.

- Automatic feeder (in-line or off-line).
- Chlorine generator - Approved for use. Releases chlorine from salt.

Ask your Doughboy dealer to recommend the best type of dispenser for your pool and area conditions. Follow manufacturer's instructions for correct use.

WITHOUT DISPENSER

Dry Chlorine: Use granules or powder only. Never pour dry chlorine directly into the pool water. Mix with pool water in a clean plastic container following chlorine manufacturer's safety instructions. When all chlorine has dissolved, pour solution into pool water at the return fitting. Water returning to the pool will properly distribute chlorine.

Liquid Chlorine: Liquid chlorine concentrate may be poured directly into pool water. Carefully add liquid chlorine to water at the return fitting. Water returning to the pool will distribute the chlorine. Follow chemical manufacturer's instructions for use of liquid chlorine.

EMPTY SKIMMER BASKET

Stop pump. Remove skimmer lid (1) to clean skimmer basket (3). **CAUTION:** Before lifting basket out, check for "STILL ALIVE" insects such as hornets, bees, etc. that could sting you. Then slowly lift basket out and empty it. Replace basket and lid. Start pump to resume normal skimmer operation. Clean basket regularly.

VACUUMING

Empty the skimmer basket prior to vacuuming. Clean the filter following manufacturer's instructions.

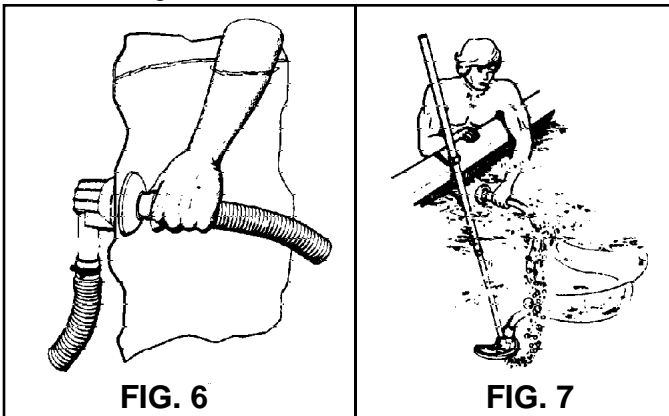

1. Stop pump. Assemble vacuum head, handle and hose (A good smooth bore 1-1/2" hose will give the best vacuuming results). Attach free end of hose to the double tapered end of vacuum adaptor (18).

2. Start pump. Hold the free end of the hose against the return fitting discharge. This will force air from the hose. When the bubbles cease to rise from the vacuum head, all the air is removed. (Fig. 6 and Fig. 7). Stop pump.

3. Bend the vacuum port cover (15) to the down position. Insert the tapered end of the vacuum adaptor with hose attached into exposed opening using a twisting motion. (Fig. 8).

4. The lid (1) performs two functions. In normal position, it covers the top of the filter. During vacuuming, this same lid becomes the sealing plate for the vacuuming. Be sure pump is "OFF". Remove the lid, rotate it 90° and lower it inside (handle grip up) to rest above the basket. Make sure air is not trapped under the lid. Trapped air will cause the lid to rise.

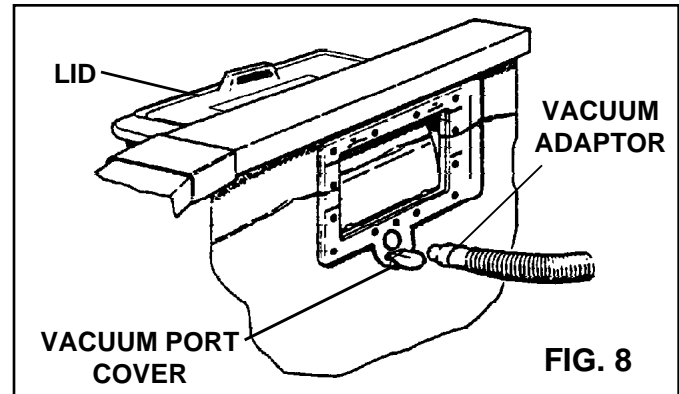

CAUTION: Never attempt to install the lid in the vacuuming position while your pump is running. The lid may suddenly be drawn down into position due to the pump's high suction action. You may injure your hands or fingers.

5. With the lid in place, start pump and operate vacuum over pool floor.

6. When finished vacuuming, stop pump. Remove the vacuum hose with vacuum adaptor attached from the pool. Clean the skimmer basket and your filter. Move the lid to the original position on top of the skimmer. Start pump to resume normal skimmer operation.

WINTERIZING (FREEZING CLIMATES)

We strongly recommend, for the protection of your skimmer, liner and pool wall, that you install the DOUGHBOY winterizing cover (30). The cover will allow you to winterize your pool without removing your skimmer, and should eliminate any possibility of damage to it due to winter weather. **CAUTION:** Removing the skimmer without installing a winterizing kit is very dangerous to the pool wall, liner, and pool installation, and voids any warranty. Filter damage caused by freezing temperatures is not covered by product warranty.

1. Drain pool to 6 inches below the eyeball return fitting.
2. Remove skimmer from pool, clean and store.
3. Install the DOUGHBOY winterizing cover by snapping it over the skimmer faceplate.

4. Remove the return fitting eyeball by unscrewing the cover. Replace the eyeball with the shut-off disc (10) and reinstall the cover. **NOTE:** The shut-off disc can be useful for plugging off the return fitting should maintenance be required on the filter or pump.

5. Drain all water from the filter, hoses, and pump. disconnect and store all filter components in a warm, dry place for the winter.

6. For spring start-up, remove the winterizing cover and hookup the filter following the instructions in your filter owner's guide. Fill pool to a level between the marks on your skimmer faceplate. Remove winterizing disk from the return fitting.

REPAIR & MAINTENANCE

Contact your local Doughboy dealer for original replacement parts. Retain this owner's guide for reference when ordering parts. Periodically inspect faceplate screws for tightness. Retighten if loose.

EXPLODED PARTS

Deluxe Thru-Wall Skimmer

MODELS 0-2094-023 / 0-2094-025

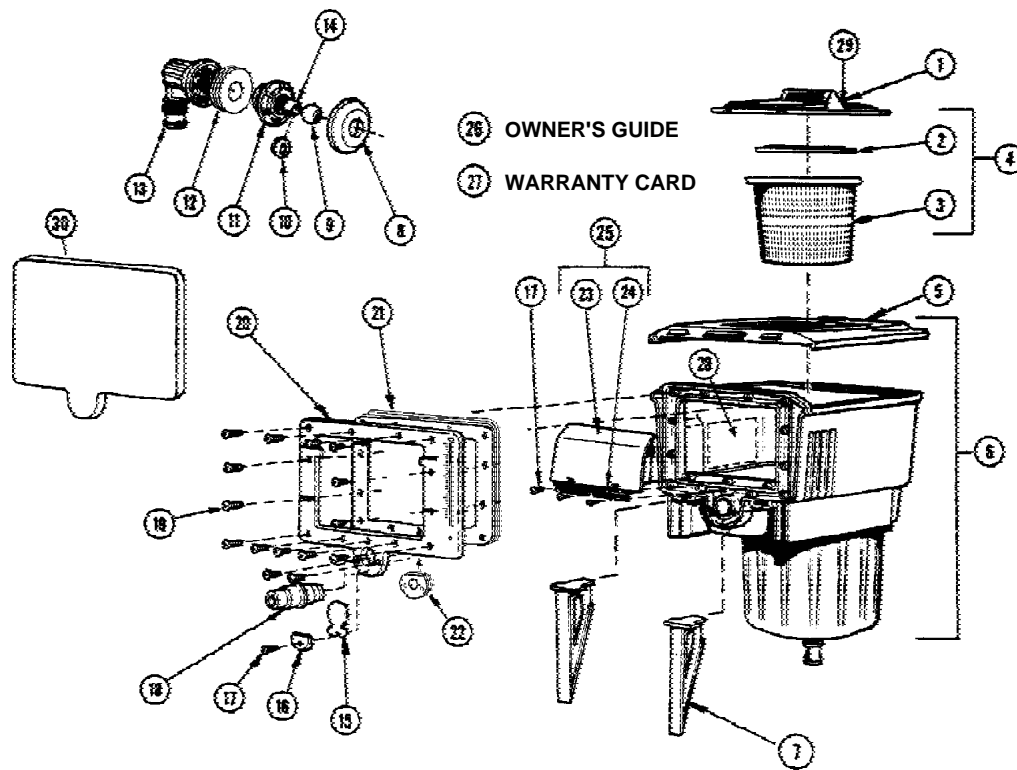

MODEL 0-2094-023 PARTS LIST (Almond)

ITEM	P/N	QTY	DESCRIPTION	ITEM	P/N	QTY	DESCRIPTION
1	1107-1356	1	Lid & Caution Label Assy.	16	340-1271	1	Vac Port Cover Retainer
2	321-1002	1	Basket Handle	17	330-1008	4	#8 x 1/2" Screw
3	340-1139	1	Basket	18	340-1253	1	Vacuum Hose Adaptor
4	1116-1045	1	Basket Assembly	19	330-1004	15	#12 x 27/32" Screw
5	340-1232	1	Light Oak Cover	20	340-2319	1	Faceplate
6	1121-1703	1	Deluxe Skimmer & Decal Assy.	21	307-1029	1	Upper Faceplate U-Gasket
7	340-1248	2	Support Brace	22	307-1030	1	Lower Faceplate U-Gasket
8	340-1238	1	Return Fitting Cover	23	1119-1032	1	Weir Float
9	348-1027	1	Eyeball	24	340-1173	1	Weir Hinge
10	340-1240	1	Shut-off Disc	25	1119-1033	1	Weir Assembly
11	340-1237	1	Return Fitting Adaptor	26	365-1889	1	Owner's Guide
12	307-1031	1	Return Fitting U-Gasket	27	---	1	Warranty Card
13	340-1773	1	Return Fitting Body	28	360-1977	1	Operating Instructions Label
14	340-1278	1	Eyeball Insert	29	360-1795	1	Caution Label
15	348-1028	1	Vac Port Cover	30	340-2321	1	Winterizing Cover

MODEL 0-2094-025 PARTS LIST (Gray)

ITEM	P/N	QTY	DESCRIPTION	ITEM	P/N	QTY	DESCRIPTION
1	1107-1356	1	Lid & Caution Label Assy.	16	340-2089	1	Vac Port Cover Retainer
2	321-1002	1	Basket Handle	17	330-1008	4	#8 x 1/2" Screw
3	340-1139	1	Basket	18	340-1590	1	Vacuum Hose Adaptor
4	1116-1045	1	Basket Assembly	19	330-1004	15	#12 x 27/32" Screw
5	340-2032	1	Gray Cover	20	340-2360	1	Faceplate
6	1121-1704	1	Deluxe Skimmer & Decal Assy.	21	307-1029	1	Upper Faceplate U-Gasket
7	340-2044	2	Support Brace	22	307-1030	1	Lower Faceplate U-Gasket
8	340-1593	1	Return Fitting Cover	23	1119-1032	1	Weir Float
9	348-1027	1	Eyeball	24	340-2039	1	Weir Hinge
10	340-1594	1	Shut-off Disc	25	1119-1064	1	Weir Assembly
11	340-1592	1	Return Fitting Adaptor	26	365-1889	1	Owner's Guide
12	307-1031	1	Return Fitting U-Gasket	27	---	1	Warranty Card
13	340-1591	1	Return Fitting Body	28	360-1976	1	Operating Instructions Label
14	340-1595	1	Eyeball Insert	29	360-1794	1	Caution Label
15	348-1028	1	Vac Port Cover	30	340-2321	1	Winterizing Cover

IMPORTANT FILTER/PUMP SAFETY

1. **DO NOT** install pump on a deck. It could fall into the water, causing severe electrical shock. Do not install on any surface at, above, or slightly below the top rail of the pool.
2. **DO NOT** allow children or adults to climb, sit, or stand on the filter or pump units. They could easily fall. Position filter and pump approximately five (5) feet from pool wall so they may not be used as steps by children.
3. **CAUTION** pool users to stay away from the skimmer opening. Strong suction can pull hair into the opening, trapping the person and causing injury.
4. **FAILURE** to keep faceplate mounting screws and return fitting tight may cause leakage between skimmer and pool wall. Continued leakage may cause wall damage which eventually may result in pool wall failure.
2. **ALWAYS STOP PUMP** before you service, tighten, or adjust the filter assembly.
3. **ALWAYS BE SURE THE GROUND UNDER YOUR FEET, AND YOUR BODY, IS DRY** before you touch filter or pump electrical equipment. Failure to heed this warning may cause personal injury due to severe electrical shock.
4. **ALWAYS** have a qualified electrician service your system if electrical problems occur.
5. **ALWAYS** have a qualified electrician install a Ground Fault Circuit Interrupter (GFCI) breaker at the electrical service or supply panel. Follow GFCI manufacturer's operating instructions for testing. Failure to do so may cause personal injury due to severe electrical shock.

SERVICING SAFETY TIPS

1. **ALWAYS TURN "OFF"** the main power switch and the Ground Fault Circuit Interrupter (GFCI) breaker switch so power is completely off before servicing your unit.

CAUTION: To reduce the risk of electrical shock, connect only to grounding type receptacles. A Ground Fault Circuit Interrupter (GFCI) must be provided in accordance with Article 680 of the National Electrical Code (NEC) and local codes or ordinances.

CAUTION: To reduce the risk of electrical shock, use only Original Equipment Manufactured (OEM) replacement parts when servicing.



Important! Above-ground pools are designed for swimming and wading only. **Do not Dive or Jump!** Misuse of your pool may result in crippling injury and/or other dangers to life and health. Do not use slides, diving boards, or any other platform or object which can be used for improper pool entry. Use only an above-ground swimming pool ladder or entry system to enter or exit your pool. **Never attempt to swim or reach behind ladders or any other pool entry system.** It is the pool owner's responsibility to secure the pool against unauthorized, unsupervised or unintentional entry. It is also the pool owner's responsibility to warn all pool users of the hazards of diving into shallow water: paralyzing injury may result. Always obey all safety rules. Remember, pool safety is everybody's responsibility.

Safety decals and caution information provided with your pool have been endorsed by the U.S. Consumer Product Safety Commission. It is mandatory that the pool owner and installer follow the installation and use directions for all provided safety signs and decals. Juveniles must be supervised at all times by a responsible adult as directed by the USCPSC.

Change of Design: Doughboy Recreational expressly reserves the right to change or modify the design and construction of any product in due course of their manufacturing procedures, without incurring any obligation to furnish or install such changes or modifications on products previously or subsequently sold.



DOUGHBOY RECREATIONAL • 10959 Jersey Blvd. • Rancho Cucamonga, CA 91730
Visit our website at www.doughboy-pools.com